



KOVOSVIT MAS
machine your future

MULTICUT Line

Multi-tasking turning milling machining center

500i / 630



Improvement of your productivity
just gets started...





Productivity

Driveshaft

- Part of shearers drive, mining machines
- Body for epicyclic gearing



Your manufacturing productivity after multitasking machine integration

Practically all types of machining technologies are available on one machine tool.

Benefits of MULTICUT machine tool integration:

- Substantial shortening of complete machining time
- Simplification of material flow
- Elimination of waiting times between processes
- Reduction of fixtures number
- Reduction of tools number
- Reduction of operators number
- Reduction of setup time
- High machining accuracy
- Easy repeat of machining of any kind with immediate availability of the technology

Example of machining productivity on part "Driveshaft"

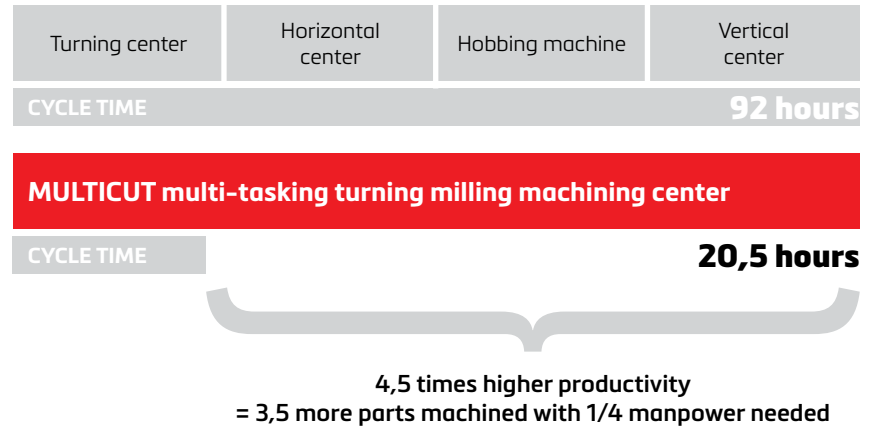

MULTICUT Line

MULTICUT 500i | 630

- Maximal machining diameter: 690 | 1150 mm
- Maximal machining length: 1600 | 1600 / 2100 / 3100 / 4600 / 6100 mm
- Main spindles power: 59 / 74 | 41 / 78 kW

MULTICUT 630 / 3000





MULTICUT 500i

MULTICUT 630 / 2000



Travels of axes

MULTICUT	500i	630 / 1500	630 / 2000	630 / 3000	630 / 4500	630 / 6000
Travel in X [mm]	640	780	780	780	780	780
Travel in Y [mm]	370	400	400	400	400	400
Travel in Z [mm]	1600	1600	2100	3100	4600	6100

Production possibilities
without any compromises...

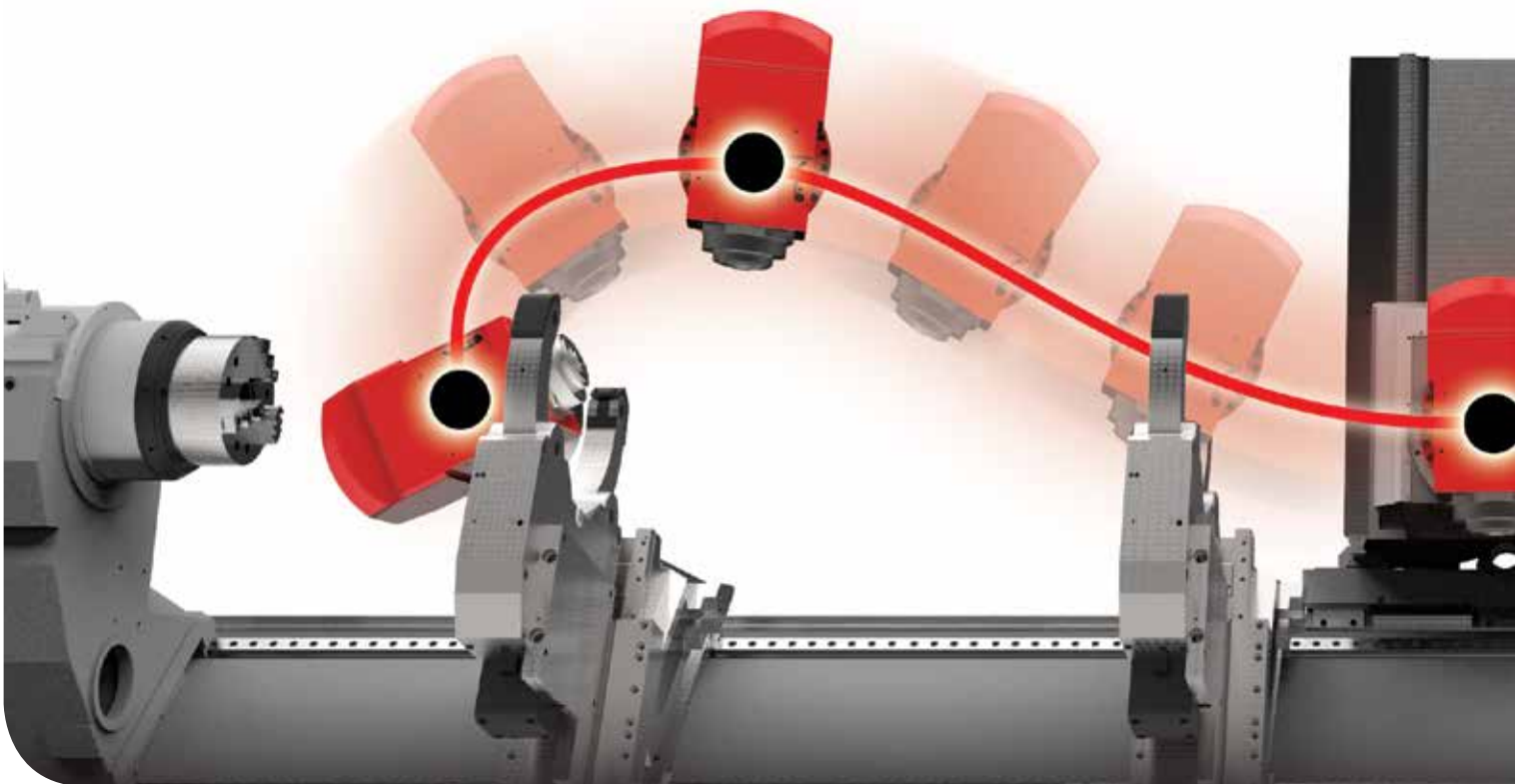



Technology **Turning + Milling =**
MULTIFUNCTIONAL

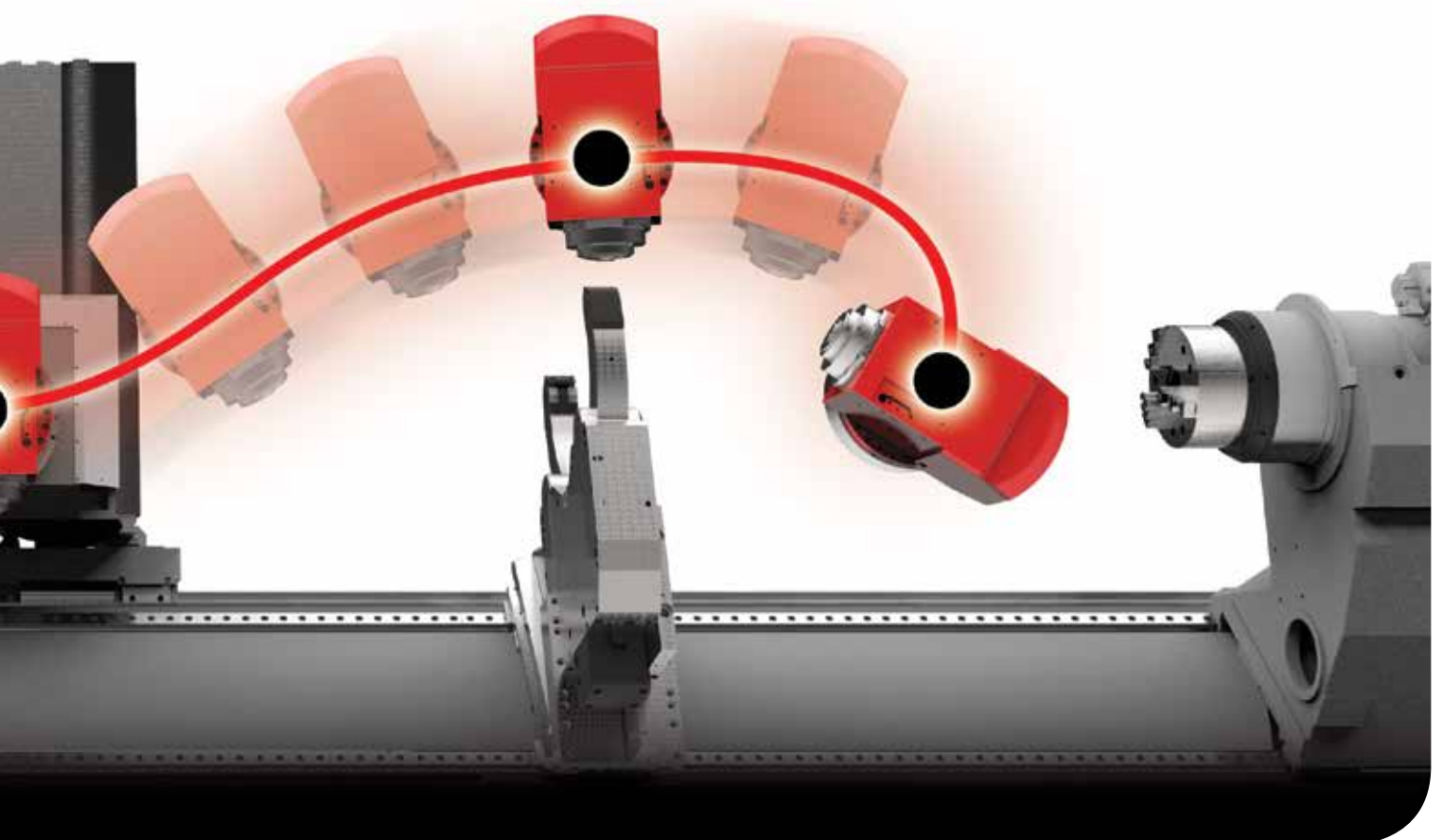

ACCURACY, RELIABILITY AND HIGH POWER

for each industry

Automotive, transport, railway industry



Compressors



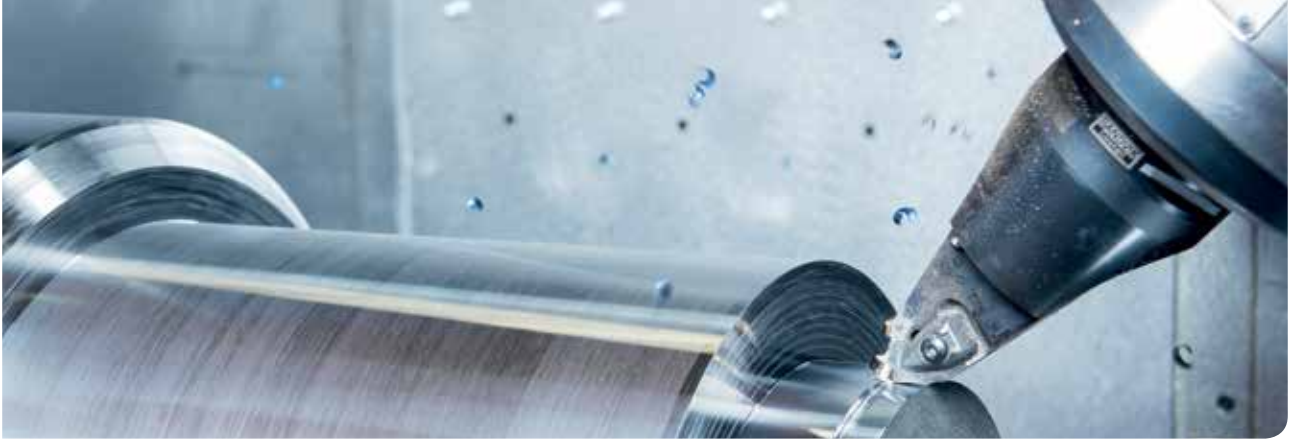

Power industry, turbines

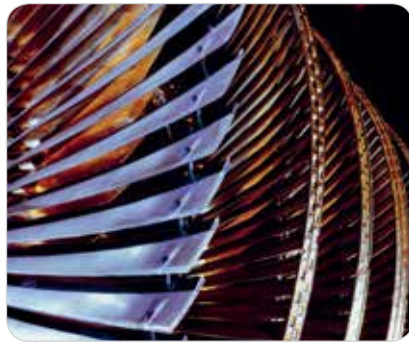

Plastics industry



Working space

Max. machining length

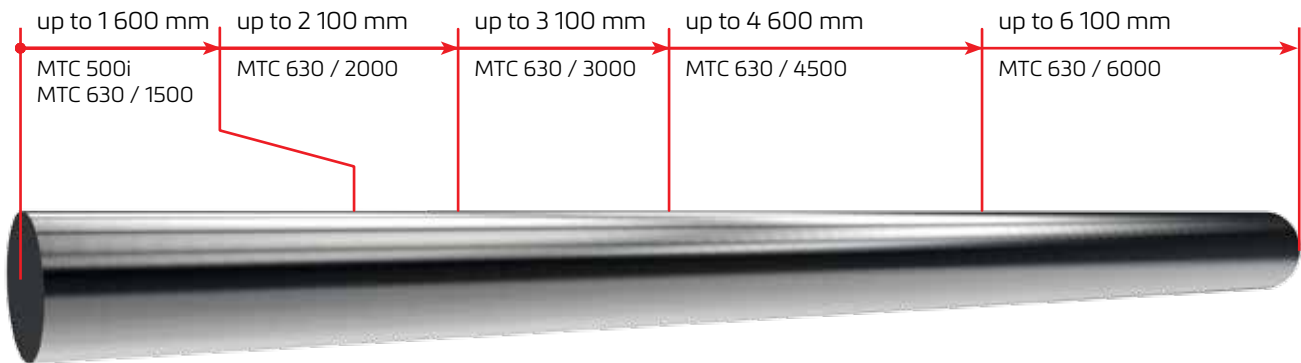

Chuck size

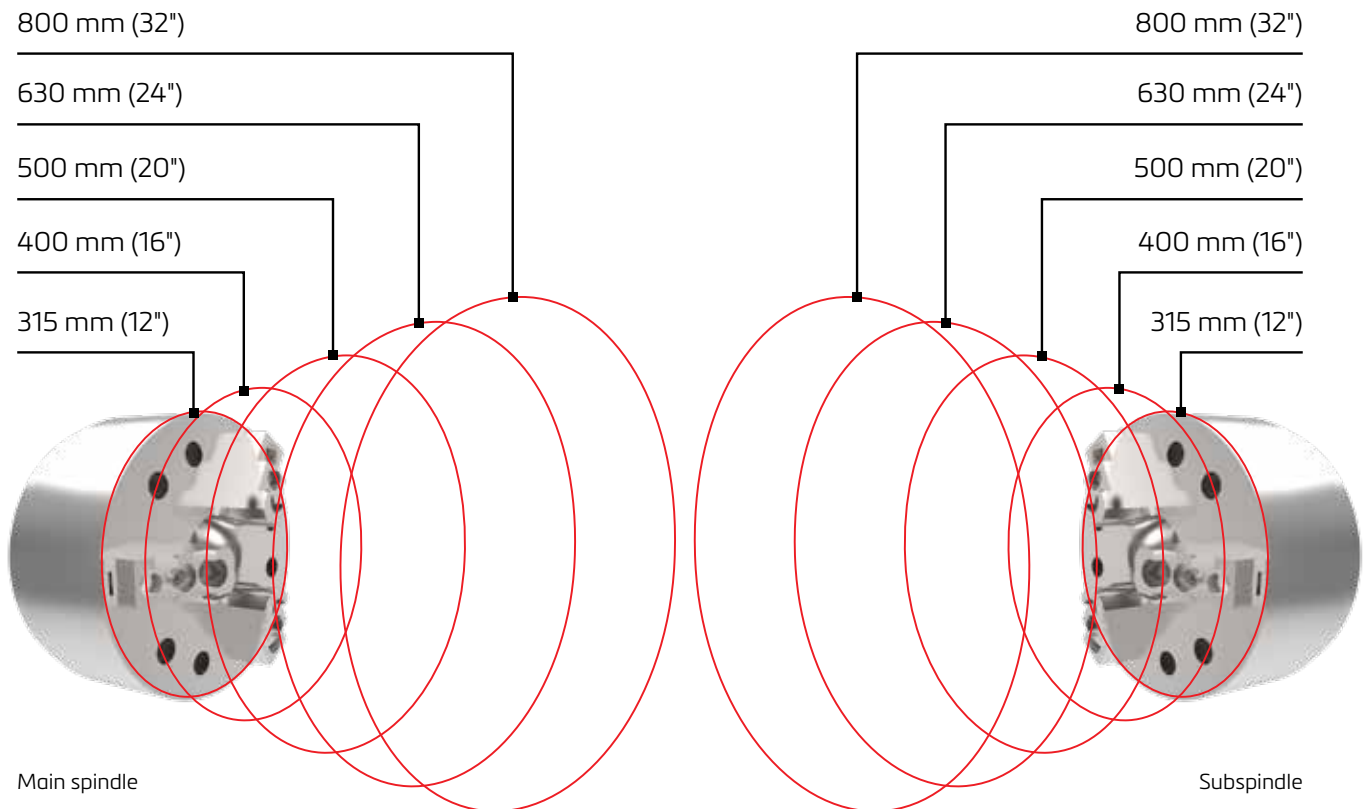



Travel in Y-axis

370 mm MTC 500i
400 mm MTC 630

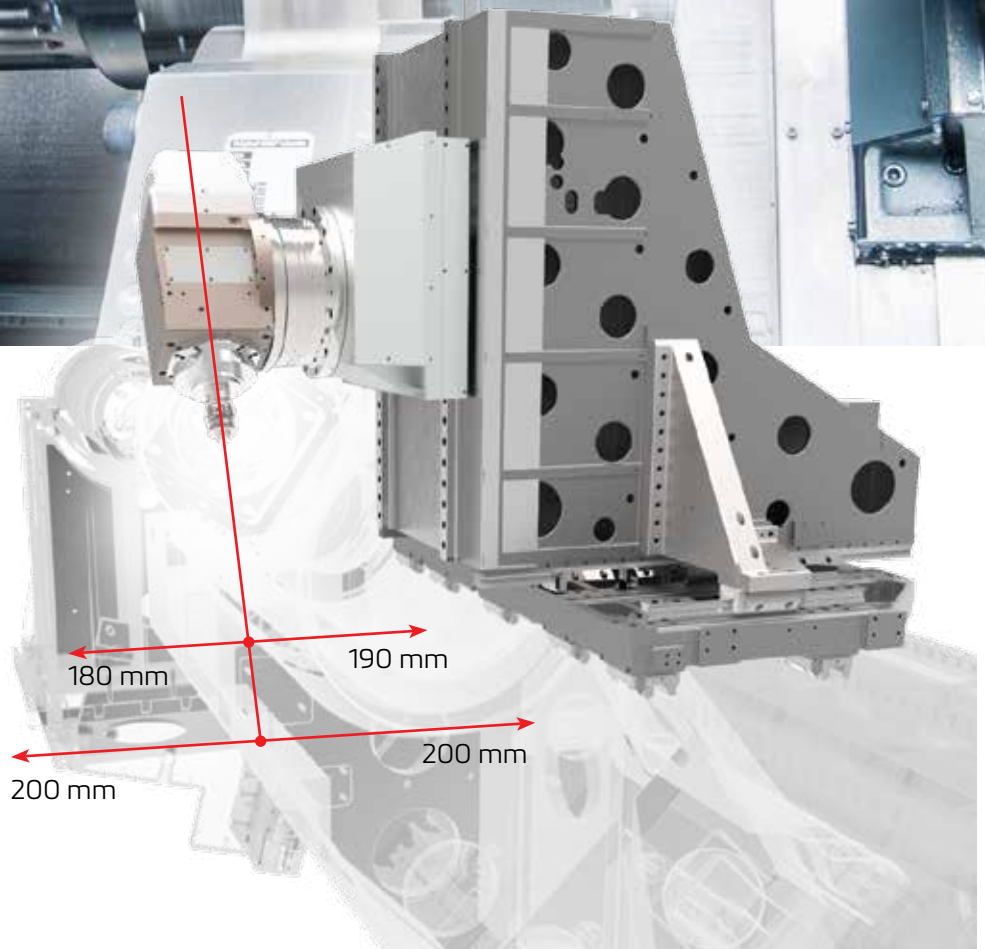

Max. machining diameter

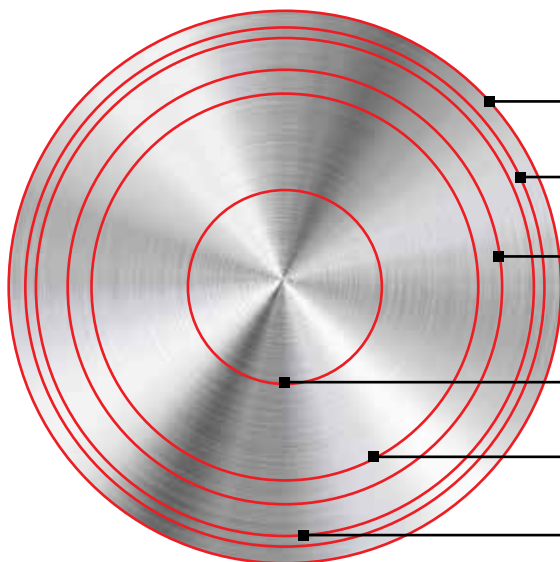

Ø 1150 mm MTC 630 (B = 0°)

Ø 1060 mm MTC 630 (B = 30°)

Ø 790 mm MTC 630 (B = 90°)

Ø 549 mm MTC 500i (B = 90°)

Ø 690 mm MTC 500i (B = 60°)

Ø 1030 mm MTC 500i (B = 0°)

Technological possibilities

the widest technological usage

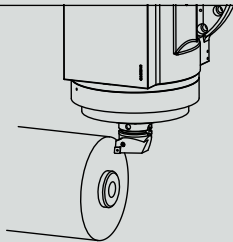

O.D. turning, threading, grooving

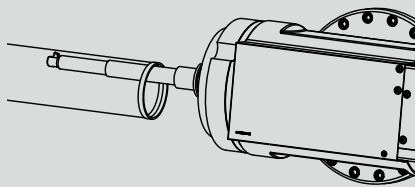

I.D. turning, threading, grooving

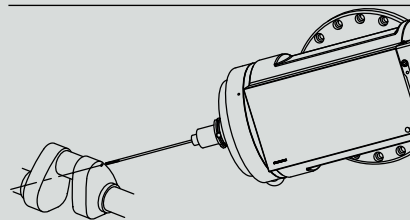

Angular drilling

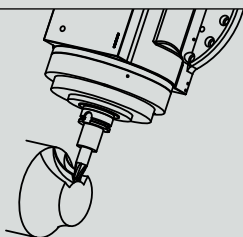

Five-axis milling

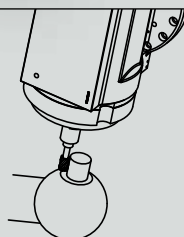

Angular milling

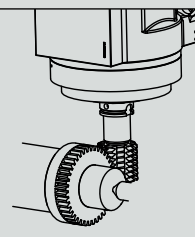

Gear hobbing and tooth milling

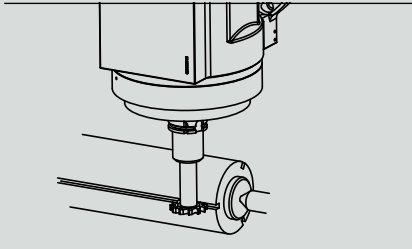

Face milling, grooving

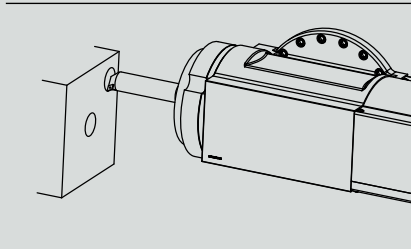

Boring

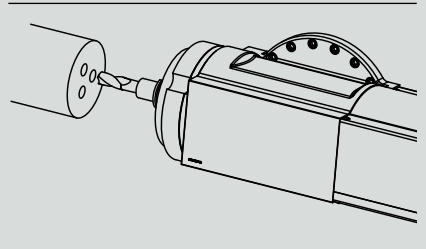

Drilling

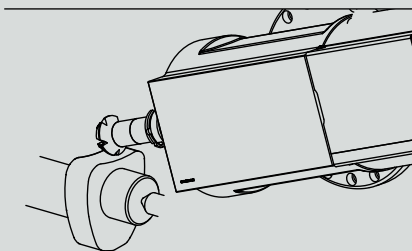

Cam + crank shaft milling

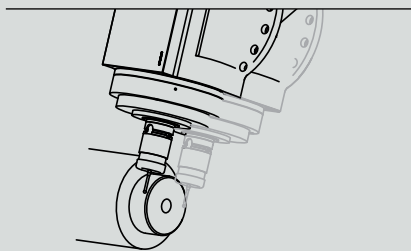

In-process measuring

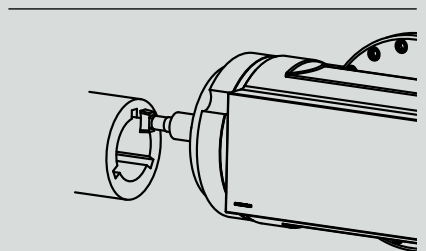

Slotting

MULTICUT 500i machine body

**unbeatable versatility for shorter
and flanged workpieces**

Magazine capacity: 81 pcs. HSK-T63, Capto C6

3 500 min⁻¹

[2 800 min⁻¹]

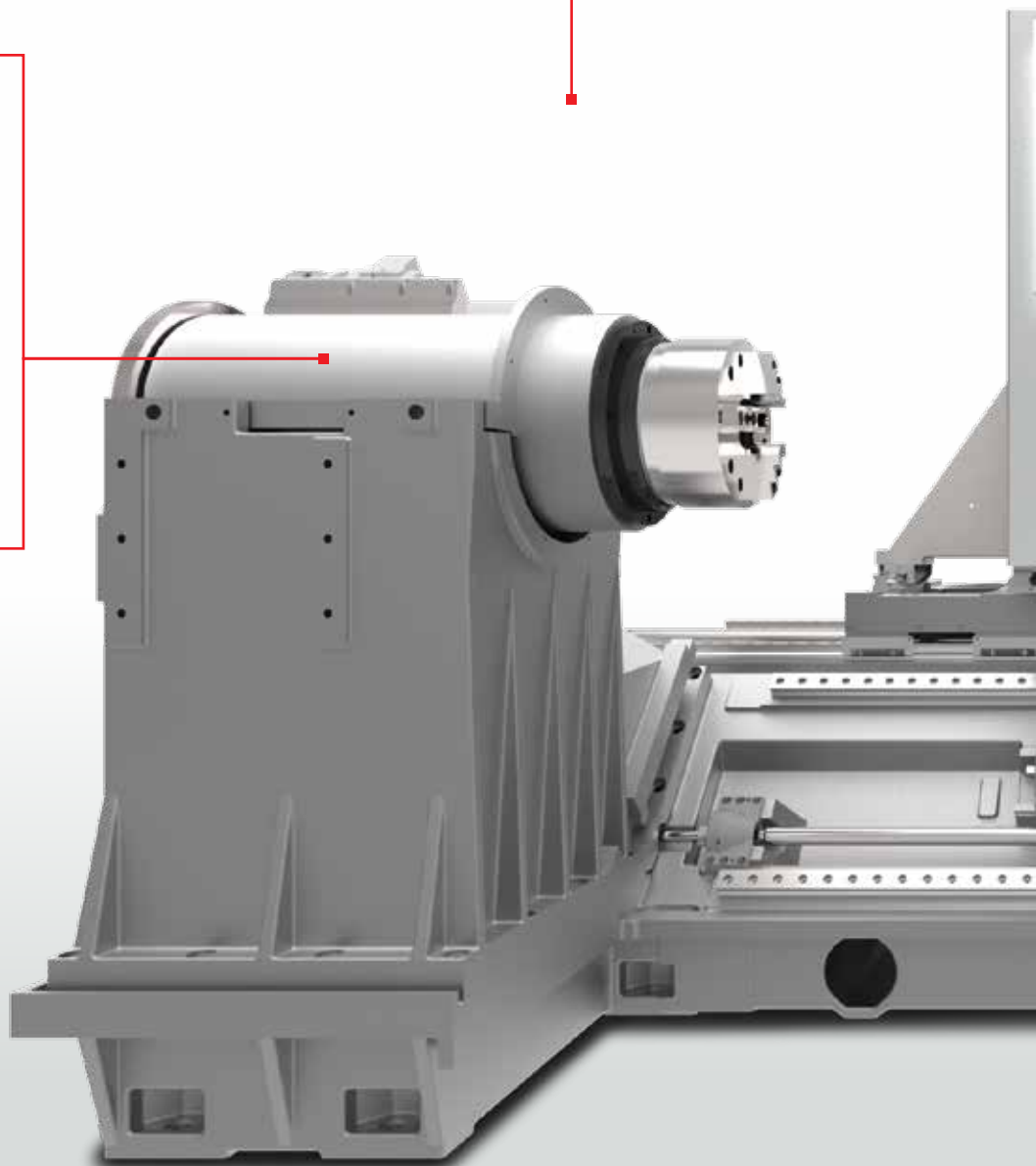



12 000 min⁻¹

3 500 min⁻¹

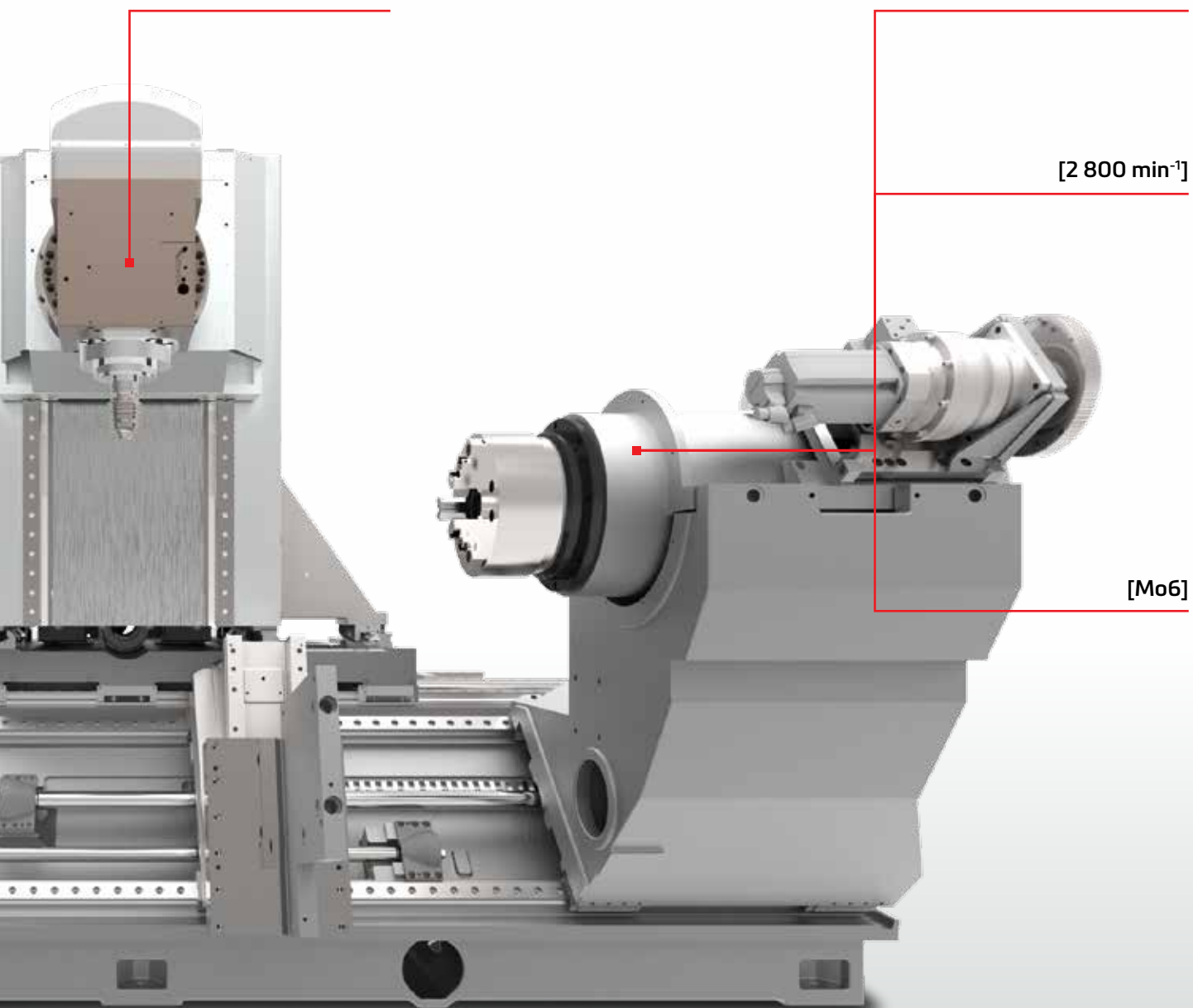

[2 800 min⁻¹]

[Mo6]

MULTICUT 630 machine body

complete machining of even the most complex workpieces up to 6 metres

Magazine capacity: 66 pcs. [120; 180] HSK 63, Capto C6
44 pcs. [80; 120] HSK 100, Capto C8

2 800 min⁻¹

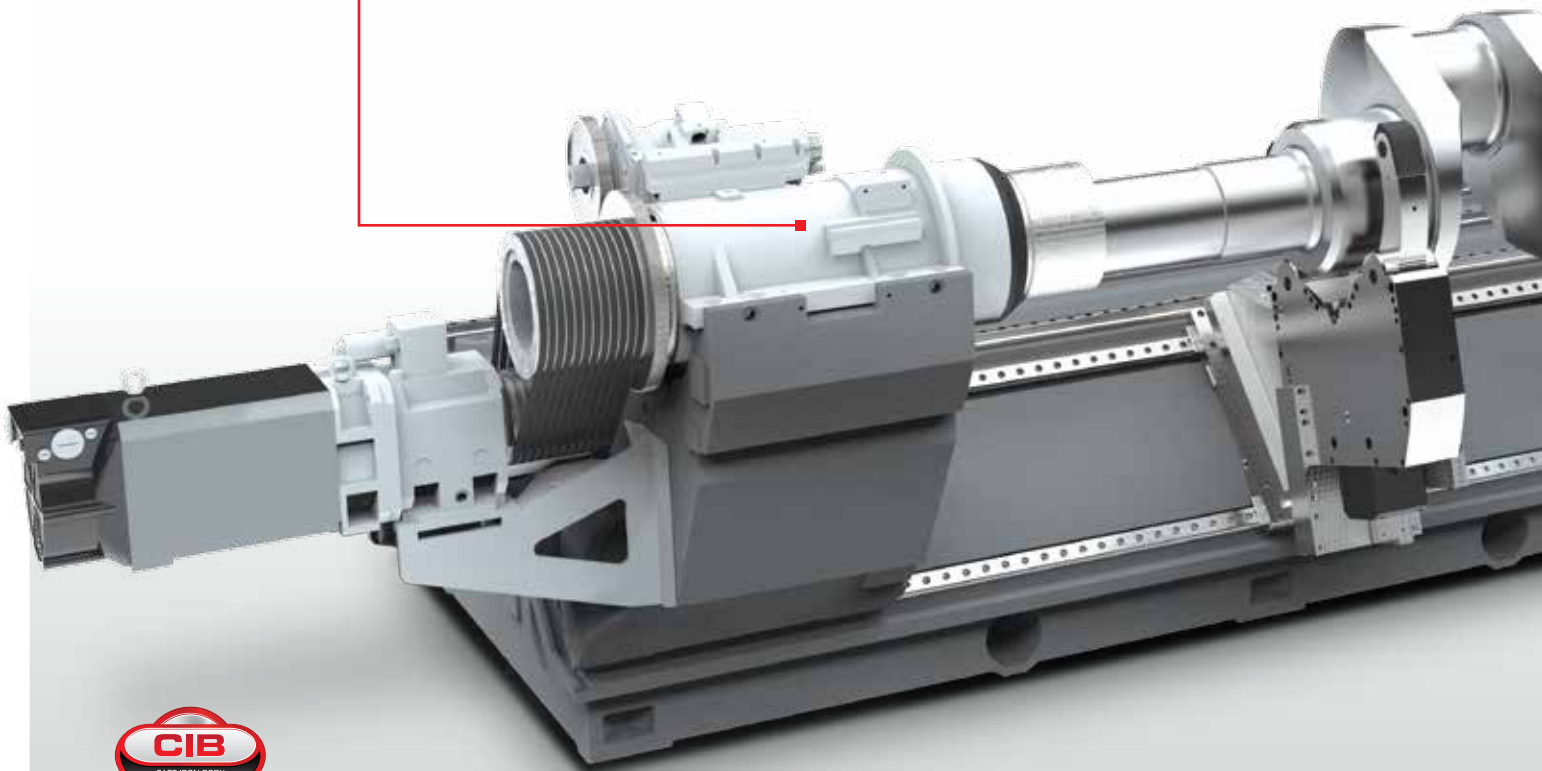



12 000 min⁻¹

[6 500 min⁻¹]

[10 000 min⁻¹]

[3 500 min⁻¹]

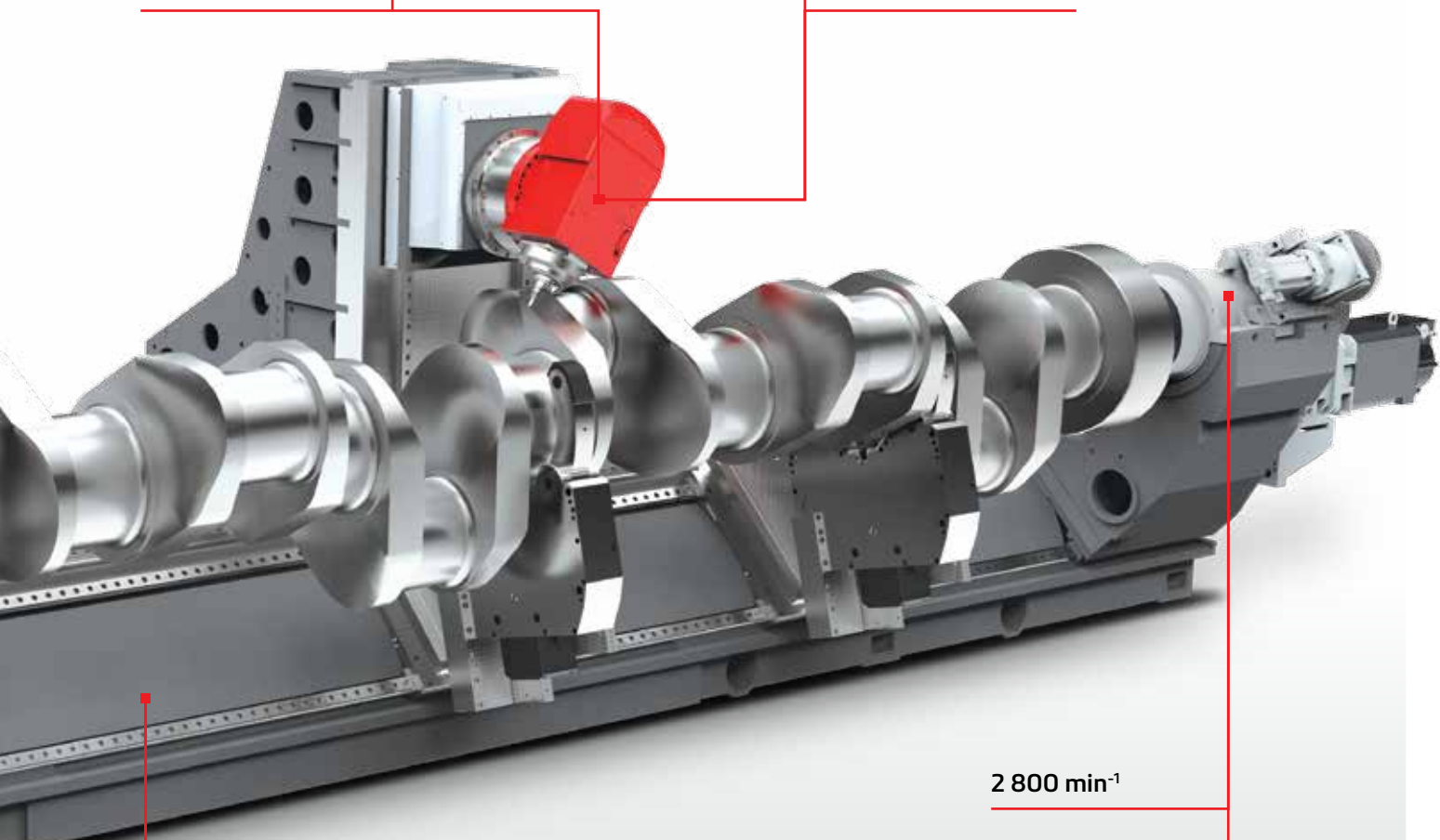

2 800 min⁻¹

Z-axis: 1 600 mm

Z-axis: 2 100 mm

Z-axis: 3 100 mm

Z-axis: 4 600 mm

Z-axis: 6 100 mm

[Mo6]

Workpiece spindles, C-axis

power and torque characteristics of the workpiece spindles

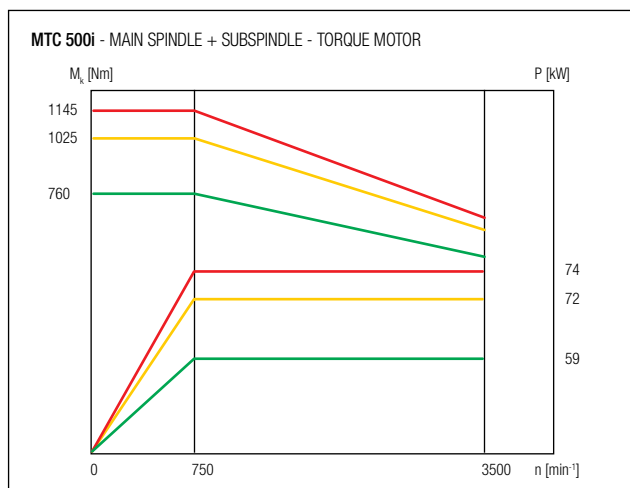
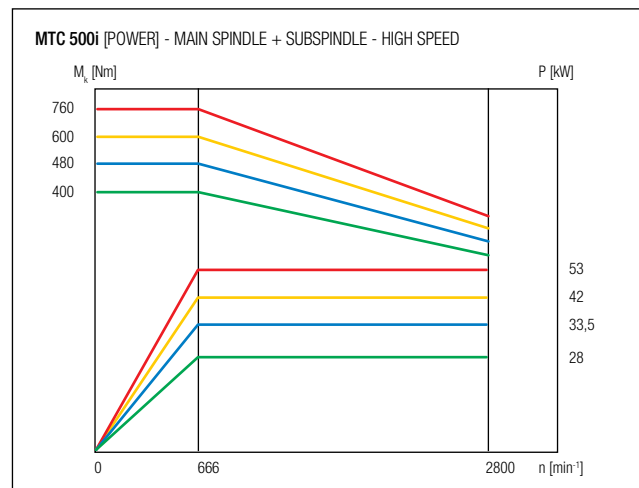
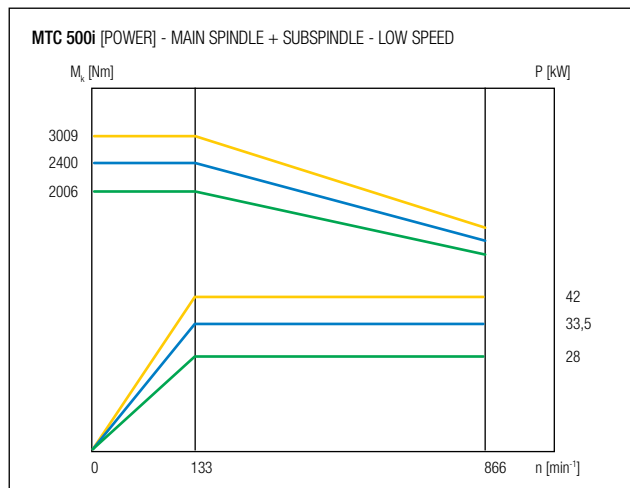

- S6 25% ED
- S6 40% ED
- S6 60% ED
- S1 100% - continuous

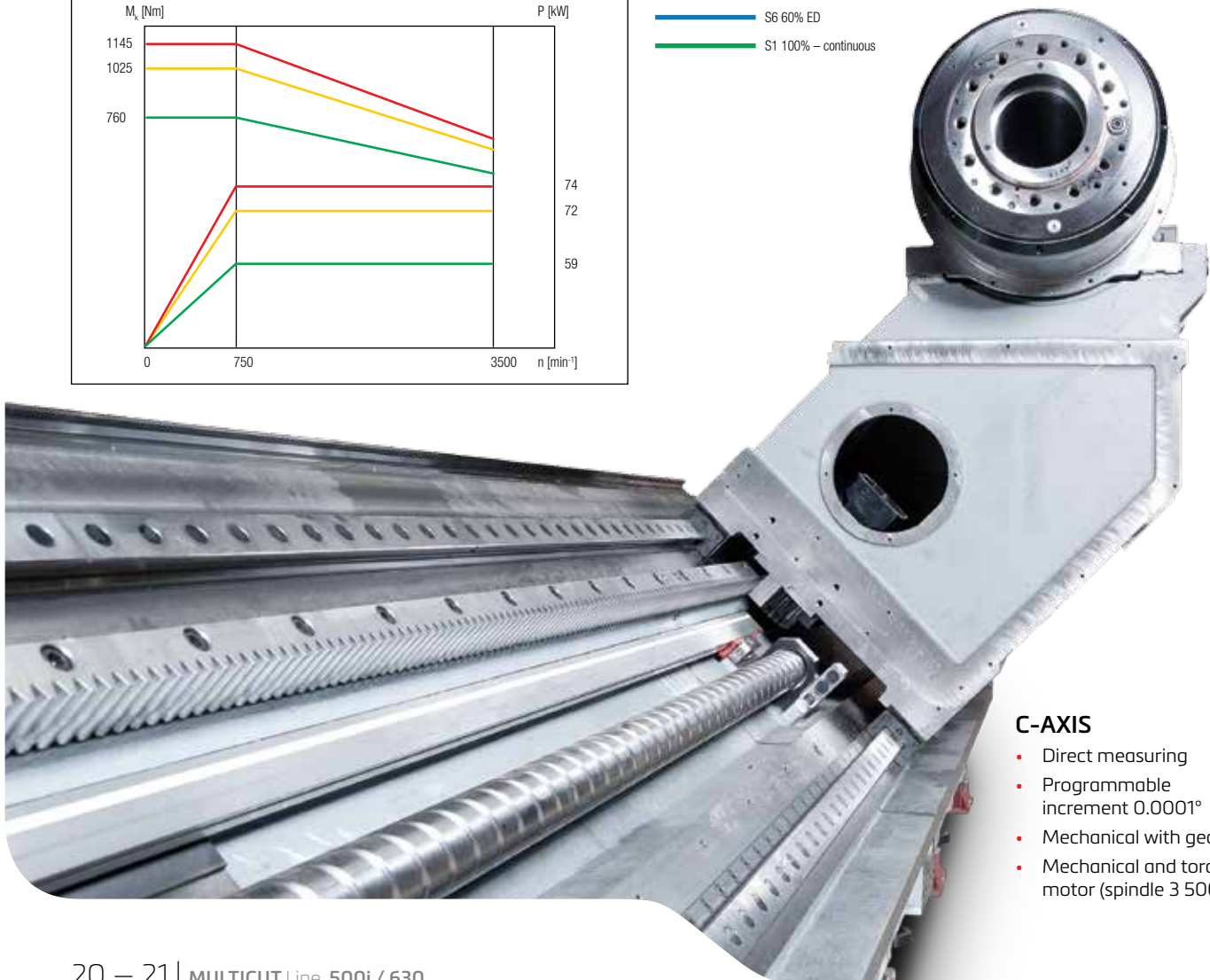

C-AXIS

- Direct measuring
- Programmable increment 0.0001°
- Mechanical with gearbox
- Mechanical and torque motor (spindle 3 500 min⁻¹)

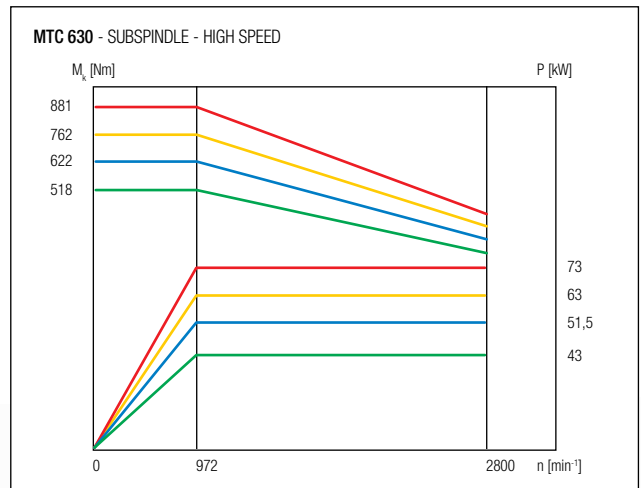
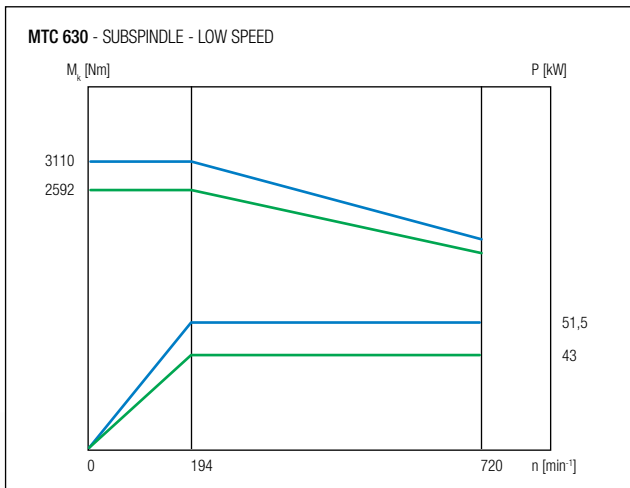
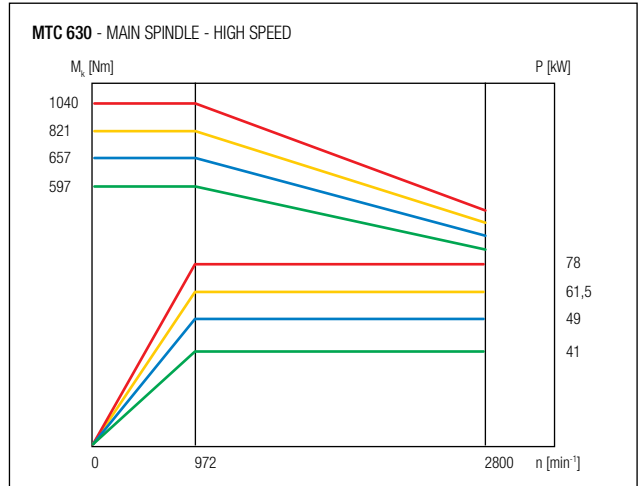
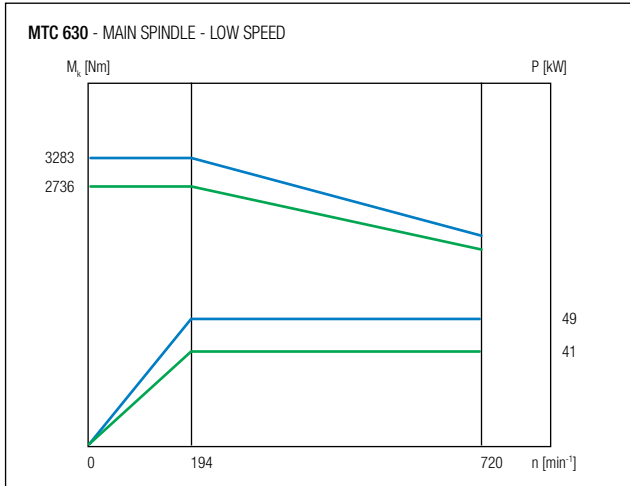

- S6 25% ED
- S6 40% ED
- S6 60% ED
- S1 100% – continuous

T specification: Tailstock
 S specification: [Subspindle with tailstock function]



Tool spindles, B-axis

power and torque characteristics of the tool spindles

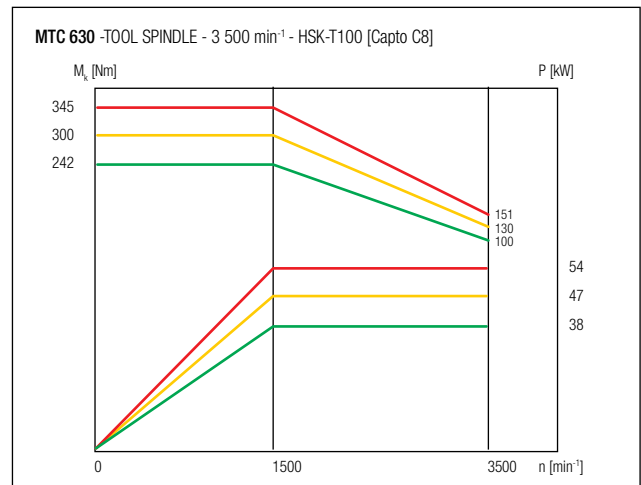
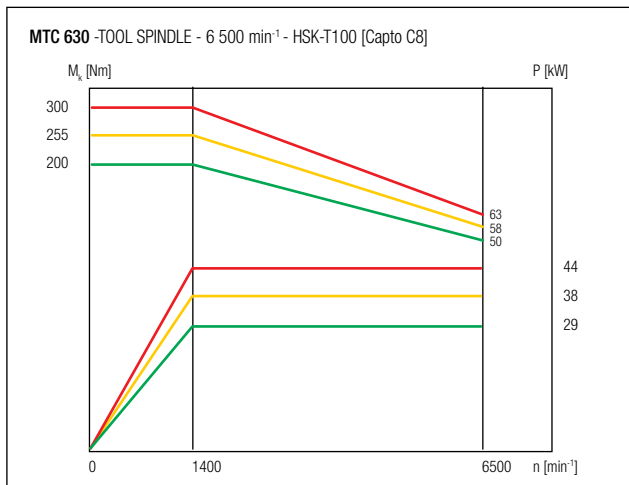
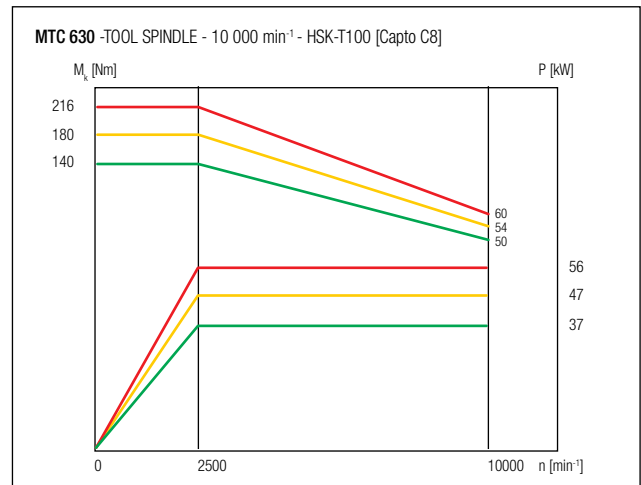
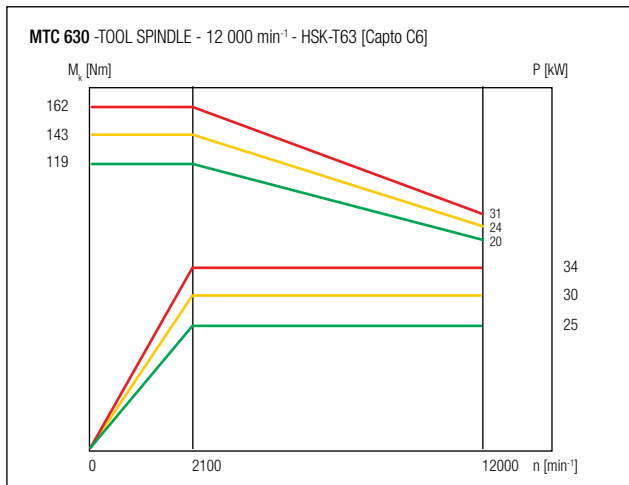
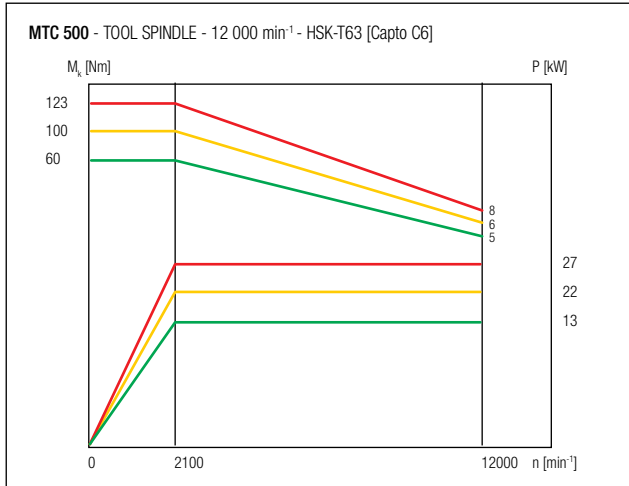

the most powerful in its class

TOOL SPINDLE

- Direct drive
- Active cooling
- Hydraulic indexing

B-axis

- Direct drive - Torque motor
- Active cooling
- Hydraulic brake
- Direct measuring
- Programmable increment 0.0001°



Deep I.D. technology

Boring bars storage capacity

- Up to the length of 1 500 mm
- Up to the diameter of 125 mm
- Automatic change of up to 3 bars

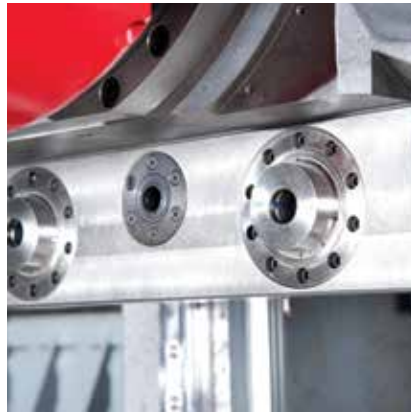
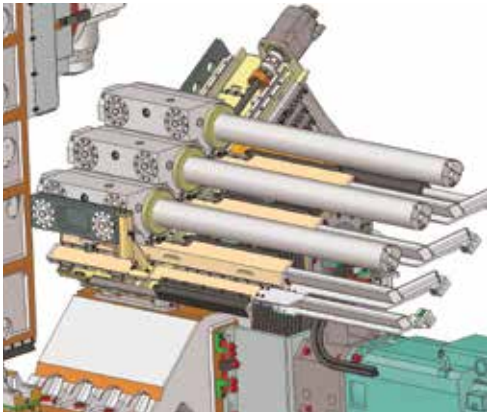

X-axis slide interface:

- Turning bars
- Boring bars



Tool spindle:

- Turning bars
- Boring bars
- Angular boring



Subspindle:

- Boring bars



MULTICUT - working space

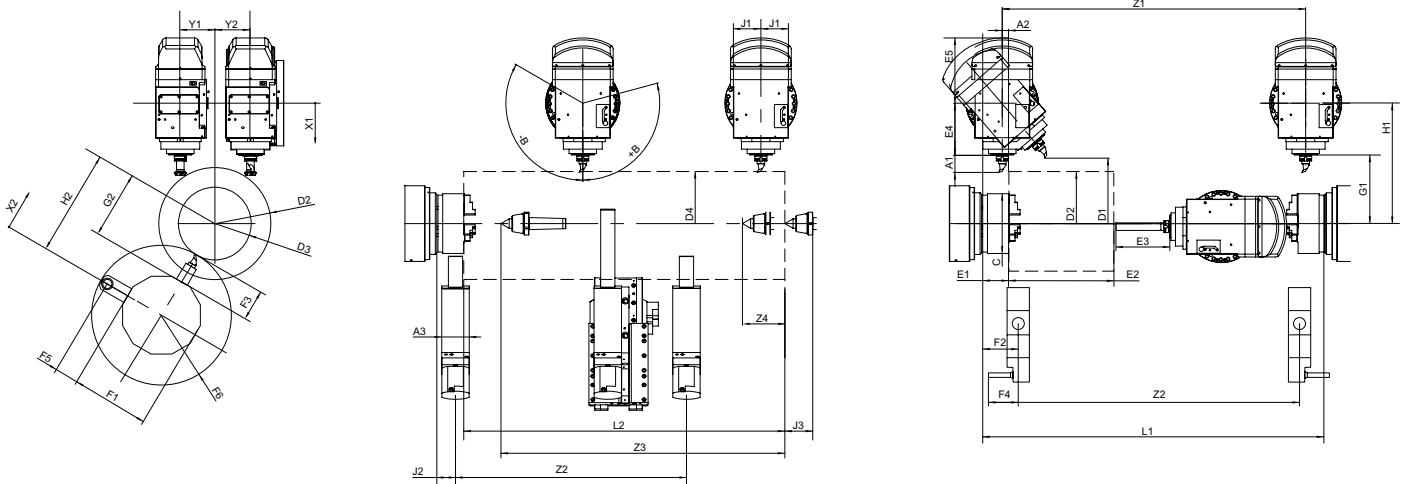

	A1 [mm]	A2 [mm]	A3 [mm]	C [mm]	-B1 / +B2 [mm]	D1 (B) [mm]	D2 [mm]	D3 [mm]	D4 [mm]	E1 [mm]	E2 [mm]	E3 [mm]
MTC 500i	70	-32,75	175 (200*)	500	120° / 105°	690 (45°)	550	-	by the steady rest type	136	552	350
MTC 630/1500	65 (80*)	45 (55*)	175 (200*)	630	120° / 120°	940 (60°)	800 (770*)	630	by the steady rest type	200	290 (255**)	300 (255**)
MTC 630/2000	65 (80*)	45 (55*)	175 (200*)	630	120° / 120°	940 (60°)	800 (770*)	630	by the steady rest type	200	460 (420**)	460 (425**)
MTC 630/3000	65 (80*)	45 (55*)	175 (200*)	630	120° / 120°	940 (60°)	800 (770*)	630	by the steady rest type	200	940 (880**)	500
MTC 630/4500	65 (80*)	45 (55*)	175 (200*)	630	120° / 120°	940 (60°)	800 (770*)	-	by the steady rest type	200	1690 (1630**)	500
MTC 630/6000	65 (80*)	45 (55*)	175 (200*)	630	120° / 120°	940 (60°)	800 (770*)	-	by the steady rest type	200	2440 (2380**)	500

	E4 [mm]	E5 [mm]	F1 [mm]	F2 [mm]	F3 [mm]	F4 [mm]	F5 [mm]	F6 [mm]	G1 [mm]	G2 [mm]	H1 [mm]	H2 [mm]
MTC 500i	279	284	by the steady rest type	-	-	-	-	-	345	-	624	-
MTC 630/1500	285	295 (410**)	by the steady rest type	500	125	240	120	720	465	440	750	630
MTC 630/2000	285	295	by the steady rest type	500	125	240	120	720	465	440	750	630
MTC 630/3000	285	295 (410**)	by the steady rest type	500	125	240	120	720	465	440	750	630
MTC 630/4500	285	295 (410**)	by the steady rest type	-	-	-	-	-	465	-	750	-
MTC 630/6000	285	295 (410**)	by the steady rest type	-	-	-	-	-	465	-	750	-

	J1 [mm]	J2 [mm]	J3 [mm]	L1 [mm]	L2 [mm]	X1 [mm]	X2 [mm]	Y1/Y2 [mm]	Z1 [mm]	Z2 [mm]	Z3 [mm]	Z4 [mm]
MTC 500i	120	by the steady rest type	102	1799	1693	640	-	180/190	1600	1218	max. 1497***	180
MTC 630/1500	145 (230**)	by the steady rest type	102	1900	1505	780	325	200/200	1600	1300	max. 1600***	180
MTC 630/2000	145 (230**)	by the steady rest type	102	2400	2005	780	325	200/200	2100	1800	max. 2100***	180
MTC 630/3000	145 (230**)	by the steady rest type	102	3400	3005	780	325	200/200	3100	2800	max. 3100***	180
MTC 630/4500	145 (230**)	by the steady rest type	102	4900	4505	780	-	200/200	4600	-	max. 4250***	180
MTC 630/6000	145 (230**)	by the steady rest type	102	6400	6005	780	-	200/200	6100	-	max. 5250***	180

Remark:

* taper Capto C8, HSK-T100

** tool spindle 12 000 rpm

*** Value depending on the configuration of the machine (lower turret, steady rest)

Tool magazine

Tool Change

- Fast tool change
- MTC 500i with static ATC arm
- MTC 630 with sliding ATC arm, for even quicker tool change
- Chip-to-chip time: 15 s (MTC 500i) / 10 s (MTC 630)
- Value depending on the configuration of the machine (lower turret, steady rest)



MULTICUT 500i / 630 configurator

Key:

■ Normal standard machine accessories □ Special (optional) machine accessories @ Machine specification on request × Unavailable machine specification

MULTICUT			500i	630/1500	630/3000	630/4500	630/6000
Workpiece spindles							
Main spindle	3500 min ⁻¹	A8, 59 kW	■	×	×	×	×
	2800 min ⁻¹	A11, 28 kW	□	×	×	×	×
	2800 min ⁻¹	A11, 41 kW	×	■	■	■	■
Sub spindle	3500 min ⁻¹	A8, 59 kW	■	×	×	×	×
	2800 min ⁻¹	A11, 28 kW	□	×	×	×	×
	2800 min ⁻¹	A11, 43 kW	×	■	■	■	■
Drive cooling			■	■	■	■	■
Spindle synchronization			□	□	□	□	□
Sub spindle adaptation for the tailstock function			□	□	□	□	□
Workpiece clamping system							
Hydraulic chuck main spindle	315 mm	A8	□	×	×	×	×
	400 mm	A8, A11	□	□	□	□	□
	500 mm	A11	□	□	□	□	□
	630 mm	A11	□	□	□	□	□
	800 mm	A11	×	□	□	□	□
Hydraulic chuck subspindle	315 mm	A8	□	×	×	×	×
	400 mm	A8, A11	□	□	□	□	□
	500 mm	A11	□	□	□	□	□
	630 mm	A11	□	□	□	□	□
	800 mm	A11	×	□	□	□	□
Tailstock	Mo6		■	■	■	■	■
Clamping cylinder, without through-hole, for main spindle			□	■	■	■	■
Clamping cylinder, with through-hole, for main spindle			■	□	□	□	□
Clamping cylinder, without through-hole, for subspindle			■	■	■	■	■
Clamping cylinder, with through-hole, for subspindle			□	□	□	□	□
Adjustable pressure for clamping in the chuck			■	■	■	■	■
Two adjustable pressures in the chuck			×	□	□	□	□
Centre air blow of jaws for the main spindle			□	□	□	□	□
Centre air blow of jaws for the subspindle			■	□	□	□	□
Other air blow of jaws			@	@	@	@	@
Hard jaws as selected			□	□	□	□	□
Soft jaws as selected			□	□	□	□	□
Rotary center into the subspindle	Mo6		□	□	□	□	□
Rotary center for tailstock	Mo6		□	□	□	□	□
Flange for the face carrier			□	□	□	□	□
Face carrier			□	□	□	□	□
Collet chuck with 1 pc. of collet			□	□	□	□	□
Self-centring NC controlled steady rest with X axis slide; limitation of swing diameter	SR 5	(ø45 mm - ø310 mm; ø530mm)	□	×	×	×	×
	SR 5	(ø45 mm - ø310 mm; ø595mm)	×	□	□	□	□
	SR 5.1	(ø85 mm - ø350 mm; ø480mm)	□	×	×	×	×
	SR 5.1	(ø85 mm - ø350 mm; ø630mm)	×	□	□	□	□
	K5.1	(ø100 mm - ø410 mm; ø630mm)	×	□	□	□	□
Self-centring NC controlled steady rest without X axis slide; limitation of swing diameter	K6	(ø125 mm - ø460 mm; ø460mm)	×	□	□	□	□
	K6.1	(ø215 mm - ø510 mm; ø510mm)	×	□	□	□	□
Maximum number of steady rests in machine, including the lower turret	1 pcs.		□	□	□	□	□
	2 pcs.		×	×	□	□	□
	3 pcs.		×	×	×	□	□
Bar feeder (+ adaptation)			□	□	□	□	□
Bar guiding			□	□	□	□	□
Workpiece manipulation system			□	□	□	□	□
Machining tool system							
Tool spindle	12000 min ⁻¹	13 kW, HSK-T63	■	×	×	×	×
	12000 min ⁻¹	13 kW, Capto C6	□	×	×	×	×
	12000 min ⁻¹	25 kW, HSK-T63	×	■	■	■	■
	12000 min ⁻¹	25 kW, Capto C6	×	□	□	□	□
	10000 min ⁻¹	37 kW, HSK-T100	×	□	□	□	□
	10000 min ⁻¹	37 kW, Capto C8	×	□	□	□	□
	6500 min ⁻¹	29 kW, HSK-T100	×	□	□	□	□
	6500 min ⁻¹	29 kW, Capto C8	×	□	□	□	□
	3500 min ⁻¹	38 kW, HSK-T100	×	□	□	□	□
	3500 min ⁻¹	38 kW, Capto C8	×	□	□	□	□
Lower turret			×	□	□	×	×
Deep boring / turning	Tool spindle		□	□	□	□	□
	X axis slide		×	□	□	□	□
	Subspindle		@	□	□	□	□
Active cooling of the B-axis and tool spindle drive			■	■	■	■	■
Workpiece manipulation system			@	@	@	@	@

MULTICUT			500i	630/1500	630/3000	630/4500	630/6000
Tool magazine							
Number of tools in magazine	81 pcs.	HSK-T63, Capto C6	■	×	×	×	×
	66 pcs.	HSK-T63, Capto C6	×	■	■	■	■
	44 pcs.	HSK-T100, Capto C8	×	□	□	□	□
	80 pcs.	HSK-T100, Capto C8	×	□	□	□	□
	120 pcs.	HSK-T63/100, Capto C6/C8	×	□	□	□	□
180 pcs.	HSK-T63, Capto C6	×	□	□	□	□	
Automatic change of boring bars	3 pcs.	1500 mm / ø125 mm	×	□	□	□	□
Cooling and work area							
External coolant supply with filtering	7 bar		■	■	■	■	■
Through-spindle coolant system with filtering	20 bar		□	□	□	□	■
Through-spindle coolant system with filtering	70 bar		□	□	□	□	□
Internal coolant supply with air			@	@	@	@	@
External coolant supply with air			@	@	@	@	@
Coolant tank thermal stabilisation			□	□	□	□	□
Lower turret tool cooling	7 bar		×	■	■	■	■
Lower turret tool cooling	17 bar		×	□	□	□	□
Automatic rinsing of work area			■	■	■	■	■
Manual rinsing of work area			□	□	□	□	□
Work area lighting			■	■	■	■	■
Visiport spin windows in the sliding doors			×	□	□	□	□
Exhaustion of vapours from work area			□	□	□	□	□
Chip conveyor			■	■	■	■	■
Measuring							
Manual tool probe - arm			□	×	×	×	×
Automatic tool probe on the telescopic arm			□	□	□	□	□
Workpiece measuring touch probe			□	□	□	□	□
Operation, functions, software							
Machine automatic power-off system			□	□	□	□	□
Machine state signalling - beacon			■	■	■	■	■
Automatic opening of door			■	■	■	■	■
Indication of regular maintenance activities on machine			■	■	■	■	■
USB connector			■	■	■	■	■
Ethernet card			■	■	■	■	■
Adjustable operation panel			■	■	■	■	■
Remote control with hand wheel, digital display			■	■	■	■	■
Automatic central lubrication			■	■	■	■	■
Switchboard air conditioning			■	■	■	■	■
Remote diagnostics			□	□	□	□	□
MAS Machine Monitor			□	□	□	□	□
MAS GSM Monitor			□	□	□	□	□
Cutting process diagnostics (only for 12000min ⁻¹ spindle)			□	□	□	□	□
Siemens SHOP-TURN			■	■	■	■	■
Axis measuring for machining							
Direct measuring of X- / Y- / Z-axis of the tool spindle			■	■	■	■	■
Direct measuring system of X axis of lower turret			×	■	■	■	■
Direct measuring of Z axis of lower turret			×	□	□	□	□
Continuously controlled B-axis			■	■	■	■	■
Direct measuring of B-axis			■	■	■	■	■
Continuously controlled C-axis	Main spindle		■	■	■	■	■
	Subspindle		■	■	■	■	■
Direct measuring of C-axis	Main spindle		■	■	■	■	■
	Subspindle		■	■	■	■	■
Others							
Machine operation, maintenance manual			■	■	■	■	■
Machine handling tool kit			■	■	■	■	■
Elements for machine installation + anchoring			■	■	■	■	■
Footswitches			■	■	■	■	■
Template for machine foundation plan			□	□	□	□	□
Lifting gear			□	□	□	□	□
Working fluid warming			□	□	□	□	□
Screw air compressor			□	□	□	□	□
Chip container			□	□	□	□	□
Integrated safety elements							
Complete guard system			■	■	■	■	■
Safety glasses			■	■	■	■	■
Automatic door locking			■	■	■	■	■
Check of workpiece clamping in chuck			■	■	■	■	■

MULTICUT 500i technical data

Parameter			MULTICUT 500i [POWER]		
			T	S	
Operating range	Max. swing over bed / lower support	mm	1 030		
	Max. turning diameter	B= 90° / 60° / 45° / 0°	549 / 690 / 880 / 1 030		
	Max. distance of faces	spindle to tailstock spindle spindle to spindle	1 972	1 799	
	Max. turning length <Z-axis travel>	mm	1 693	1 527	
	Bar capacity	mm	94 [127]		
Workpiece weight	Overhung / supported with rotary center, incl. chuck (max. 300 rpm)	kg	800 / 2 100 [1 000 / 2 500]		
	Supported with steady rests 1 / 2 / 3 incl. chuck (max. 300 rpm)	kg	2 500 [3 000] / - / -		
Linear axes of the tool spindle	X / Y <-Y/+Y> / Z axis travel	mm	640 / 370 <-190+180> / 1 600		
	Feed force X ; Y ; Z	25% / 40%ED / continuous	21,5 / 17,5 / 12,5 ; 19,5 / 16 / 11,5 ; 32 / 27,5 / 17		
	X / Y / Z axis rapid traverse	m.min ⁻¹	50 / 40 / 50		
	X / Y / Z axis acceleration	m.s ⁻²	5 / 4 / 5		
Accuracy CSN ISO 230-2 VDI/DGQ 3441	Position accuracy X/Y/Z	mm	0,008/0,007/0,01		
	Repeatability X/Y/Z	mm	0,004/0,004/0,008		
Main spindle	Max. spindle speed	Low speed	3 500 [866]		
		High speed	3 500 [2 800]		
	Nominal spindle speed	min ⁻¹	750 [133 / 666]		
	Gear steps number		1 [2]		
	Spindle nose type (DIN 55026)		A8 [A11]		
	Spindle boring	mm	106 [135]		
	I.D. of the front bearings	mm	160 [200]		
	Torque	Low speed 25% / 40% / 60% ED / continuous	Nm	1 145 / 1 025 / - / 760 [- / 3 000 / 2 400 / 2 000]	
		High speed 25% / 40% / 60% ED / continuous	Nm	1 145 / 1 025 / - / 760 [760 / 600 / 480 / 400]	
Motor power	25% / 40% / 60% ED / continuous	kW	74 / 72 / - / 59 [53 / 42 / 33,5 / 28]		
Spindle axis height	mm	1 290			
Subspindle	Max. spindle speed	Low speed	-		
		High speed	3 500 [866]		
	Nominal spindle speed	min ⁻¹	-		
	Gear steps number		-		
	Spindle nose type (DIN 55026)		-		
	Spindle boring	mm	-		
	I.D. of front bearings	mm	-		
	Torque	Low speed 25% / 40% / 60% ED / continuous	Nm	-	
		High speed 25% / 40% / 60% ED / continuous	Nm	-	
Motor power	25% / 40% / 60% ED / continuous	kW	-		
C-axis of workpiece spindles	Min. programming step		0,0001°		
	Max. speed	min ⁻¹	43		
	Torque	25% ED / continuous	2 100 / 1 400		
	Brake	Nm	-		
			-		
Tool spindle	Max. speed	min ⁻¹	12 000		
	Nominal speed	min ⁻¹	2 100		
	Taper		HSK 63 / Capto 6 / [HSK 63]		
	Torque	25% / 40% ED / continuous	123 / 100 / 60		
	Power	25% / 40% ED / continuous	27 / 22 / 13		
	Number of tool indexing positions		360 × 1°		
	Spindle length	mm	563		
B axis of tool spindle	Range		-120° / +105°		
	Min. programming step		0,0001°		
	Max. speed	min ⁻¹	50		
	Time of indexing by 90°	s	0,8		
	Torque	40% ED / continuous	950 / 550		
	Hydraulic brake / locking	Nm	4 000		
Tool magazine	Tool storage capacity	HSK-T63, Capto C6	81		
		HSK-T100, Capto C8	-		
	Max. tool length	mm	350		
	Max. tool diameter	With / without adjacent HSK-T63, Capto C6	150 / 90		
		With / without adjacent HSK-T100, Capto C8	-		
	Max. tool weight	kg	8		
Tool to tool / chip to chip change time	s	3 / 15			
Tailstock	Tailstock spindle diameter / Tailstock spindle travel	mm	190 / 180	-	
	Taper for rotary center	Morse	Mo6		
	Thrust force range	kN	3,2 - 28,6	-	
Coolant tank	Tank capacity / Coolant volume	l	500 / 620		
	Pump motor power	continuous	kW		
Machine dimensions	Machine length without / with chip conveyor / for transport	mm	4 800 / 6 500 / 5 372 [6 385 / 7 425 / 6 692]		
	Machine width / for transport	mm	3 950 / 3 670		
	Machine height / for transport	mm	3 760 / 3 660		
	Machine weight	kg	22 800 [23 750]	23 050 [24 000]	
Machine connection	Electrical power supply	continuous	kVA	110 [90]	
	Compressed air supply	pressure / flow	MPa/L.min ⁻¹	0,6 / 600	
Control system	Type		Siemens Sinumerik 840D SL		
	Number of continuously controlled axes for machining		5		

[] Special (optional) machine accessories, option. The machine conforms to 

Given the unceasing development and innovations of the machines, the data in this advertising material are subject to change without notice.

MULTICUT 630 technical data

Parameter			MULTICUT 630 / 1500		
			T	S	
Operating range	Max. swing over bed / lower support	mm	1 150 / 1 020		
	Max. turning diameter	B= 90° / 60° / 45° / 0°	790 / 930 / 1 060 / 1 150		
	Max. distance of faces	spindle to tailstock spindle spindle to spindle	1 900	1 900	
	Max. turning length <Z-axis travel>	mm	1 600		
	Bar capacity	mm	122		
Workpiece weight	Overhung / supported with rotary center, incl. chuck (max. 300 rpm)	kg	1 000 / 2 500		
	Supported with steady rests 1 / 2 / 3 incl. chuck (max. 300 rpm)	kg	3 000 / - / -		
Linear axes of the tool spindle	X / Y <-Y/+Y> / Z axis travel	mm	780 / 400 <±200> / 1 600		
	Feed force X ; Y ; Z	25% / 40%ED / continuous	20,5 / 17 / 12,0 ; 25 / 20,5 / 14,5 ; 25,5 / 20,5 / 14,5		
	X / Y / Z axis rapid traverse	m.min ⁻¹	40 / 30 / 40		
	X / Y / Z axis acceleration	m.s ⁻²	4 / 4 / 4		
Accuracy CSN ISO 230-2 VDI/DGQ 3441	Position accuracy X/Y/Z	mm	0,004 / 0,004 / 0,01		
	Repeatability X/Y/Z	mm	0,002 / 0,003 / 0,006		
Main spindle	Max. spindle speed	Low speed	720		
		High speed	2 800		
	Nominal spindle speed	min ⁻¹	194 / 972		
	Gear steps number		2		
	Spindle nose type (DIN 55026)		A11		
	Spindle boring	mm	135		
	I.D. of the front bearings	mm	200		
	Torque	Low speed 25% / 40% / 60% ED / continuous	Nm	- / - / 3 283 / 2 736	
		High speed 25% / 40% / 60% ED / continuous	Nm	1 040 / 821 / 657 / 547	
	Motor power	25% / 40% / 60% ED / continuous	kW	78 / 61,5 / 49 / 41	
Spindle axis height	mm	1 325			
Subspindle	Max. spindle speed	Low speed	720		
		High speed	2 800		
	Nominal spindle speed	min ⁻¹	194 / 972		
	Gear steps number		2		
	Spindle nose type (DIN 55026)		A11		
	Spindle boring	mm	135		
	I.D. of front bearings	mm	200		
	Torque	Low speed 25% / 40% / 60% ED / continuous	Nm	- / - / 3 110 / 2 592	
		High speed 25% / 40% / 60% ED / continuous	Nm	881 / 762 / 622 / 518	
	Motor power	25% / 40% / 60% ED / continuous	kW	73 / 63 / 51,5 / 43	
C-axis of workpiece spindles	Min. programming step		0,0001°		
	Max. speed	min ⁻¹	30		
	Torque	25% ED / continuous	Nm	2 176 / 1 408	
	Brake		Nm	3 000 / 1 000	
Tool spindle	Max. speed	min ⁻¹	12 000 [10 000; 6 500; 3 500]		
	Nominal speed	min ⁻¹	2 000 [2 500; 1 400; 1 500]		
	Taper		HSK 63 [Capto C6; HSK 100; Capto C8]		
	Torque	25% / 40% ED / continuous	Nm	162/143/119 [216/180/140; 300/255/200; 345/300/242]	
	Power	25% / 40% ED / continuous	kW	34/30/25 [56/47/37; 44/38/29; 54/47/38]	
	Number of tool indexing positions		continuous [24 × 15°; 24 × 15°; 24 × 15°]		
	Spindle length	mm	695 [580; 580; 580]		
B axis of tool spindle	Range		-120° / +120°		
	Min. programming step		0,0001°		
	Max. speed	min ⁻¹	50		
	Time of indexing by 90°	s	0,8		
	Torque	40% ED / continuous	Nm	1 300 / 750	
Hydraulic brake / locking		Nm	8 000 [1 700 / 8 200]		
Tool magazine	Tool storage capacity	HSK-T63, Capto C6	66 [120; 180]		
		HSK-T100, Capto C8	44 [80; 120]		
	Max. tool length	mm	500		
	Max. tool diameter	With / without adjacent HSK-T63, Capto C6	mm	175 / 90	
		With / without adjacent HSK-T100, Capto C8	mm	200 / 130	
	Max. tool weight	kg	12		
Tool to tool / chip to chip change time	s	3 / 10			
Tailstock	Tailstock spindle diameter / Tailstock spindle travel	mm	190 / 180	-	
	Taper for rotary center	Morse	Mo6	-	
	Thrust force range	kN	2,5 - 25	-	
Coolant tank	Tank capacity / Coolant volume	l	500 / 700		
	Pump motor power	kW	0,27		
Machine dimensions	Machine length without / with chip conveyor / for transport	mm	6 630 / 7 900 / 6 630		
	Machine width / for transport	mm	5 150 / 3 100		
	Machine height / for transport	mm	3 100 / 3 000		
	Machine weight	kg	24 000 - 29 500		
Machine connection	Electrical power supply	continuous	kVA	100	
	Compressed air supply	pressure / flow	MPa/L.min ⁻¹	0,6 / 500	
Control system	Type		Siemens Sinumerik 840D SL		
	Number of continuously controlled axes for machining		5		

MULTICUT 630 / 2000		MULTICUT 630 / 3000		MULTICUT 630 / 4500	
T	S	T	S	T	S
1 150 / 1 020		1 150 / 1 020		1 150 / 1 020	
790 / 930 / 1 060 / 1 150		790 / 930 / 1 060 / 1 150		790 / 930 / 1 060 / 1 150	
2400	2400	3 400	3 400	4 900	4 900
2 100		3 100		4 600	
122		122		122	
1 000 / 2 500		1 000 / 2 500		1 000 / 2 500	
3 000 / 3 500 / -		3 000 / 3 500 / -		3 000 / 3 500 / 4 000	
780 / 400 <±200> / 2100		780 / 400 <±200> / 3 100		780 / 400 <±200> / 4 600	
20,5 / 17 / 12,0 ; 25 / 20,5 / 14,5 ; 25,5 / 20,5 / 14,5		20,5 / 17 / 12,0 ; 25 / 20,5 / 14,5 ; 25,5 / 20,5 / 14,5		20,5 / 17 / 12,0 ; 25 / 20,5 / 14,5 ; 25,5 / 20,5 / 14,5	
40 / 30 / 40		40 / 30 / 40		40 / 30 / 40	
4 / 4 / 4		4 / 4 / 4		4 / 4 / 4	
0,004 / 0,004 / 0,01		0,004 / 0,004 / 0,01		0,004 / 0,004 / 0,01	
0,002 / 0,003 / 0,006		0,002 / 0,003 / 0,006		0,002 / 0,003 / 0,006	
720		720		720	
2800		2 800		2 800	
194 / 972		194 / 972		194 / 972	
2		2		2	
A11		A11		A11	
135		135		135	
200		200		200	
- / - / 3 283 / 2 736		- / - / 3 283 / 2 736		- / - / 3 283 / 2 736	
1 040 / 821 / 657 / 547		1 040 / 821 / 657 / 547		1 040 / 821 / 657 / 547	
78 / 61,5 / 49 / 41		78 / 61,5 / 49 / 41		78 / 61,5 / 49 / 41	
1325		1 325		1 325	
-	720	-	720	-	720
-	2800	-	2 800	-	2 800
-	194 / 972	-	194 / 972	-	194 / 972
-	2	-	2	-	2
-	A 11	-	A11	-	A11
-	135	-	135	-	135
-	200	-	200	-	200
-	- / - / 3 110 / 2 592	-	- / - / 3 110 / 2 592	-	- / - / 3 110 / 2 592
-	881 / 762 / 622 / 518	-	881 / 762 / 622 / 518	-	881 / 762 / 622 / 518
-	73 / 63 / 51,5 / 43	-	73 / 63 / 51,5 / 43	-	73 / 63 / 51,5 / 43
0,0001°		0,0001°		0,0001°	
30		30		30	
2176 / 1408		2 176 / 1408		2 176 / 1408	
3000 / 1000		3000 / 1000		3000 / 1000	
12 000 [10 000; 6 500; 3 500]		12 000 [10 000; 6 500; 3 500]		12 000 [10 000; 6 500; 3 500]	
2 000 [2 500; 1 400; 1 500]		2 000 [2 500; 1 400; 1 500]		2 000 [2 500; 1 400; 1 500]	
HSK 63 [Capto C6; HSK 100; Capto C8]		HSK 63 [Capto C6; HSK 100; Capto C8]		HSK 63 [Capto C6; HSK 100; Capto C8]	
162/143/119 [216/180/140; 300/255/200; 345/300/242]		162/143/119 [216/180/140; 300/255/200; 345/300/242]		162/143/119 [216/180/140; 300/255/200; 345/300/242]	
34/30/25 [56/47/37; 44/38/29; 54/47/38]		34/30/25 [56/47/37; 44/38/29; 54/47/38]		34/30/25 [56/47/37; 44/38/29; 54/47/38]	
continuous [24 × 15°; 24 × 15°; 24 × 15°]		continuous [24 × 15°; 24 × 15°; 24 × 15°]		continuous [24 × 15°; 24 × 15°; 24 × 15°]	
695 [580; 580; 580]		695 [580; 580; 580]		695 [580; 580; 580]	
-120° / +120°		-120° / +120°		-120° / +120°	
0,0001°		0,0001°		0,0001°	
50		50		50	
0,8		0,8		0,8	
1300 / 750		1 300 / 750		1 300 / 750	
8 000 [1 700 / 8 200]		8 000 [1 700 / 8 200]		8 000 [1 700 / 8 200]	
66 [120; 180]		66 [120; 180]		66 [120; 180]	
44 [80; 120]		44 [80; 120]		44 [80; 120]	
500		500		500	
175 / 90		175 / 90		175 / 90	
200 / 130		200 / 130		200 / 130	
12		12		12	
3 / 10		3 / 10		3 / 10	
190 / 180	-	190 / 180	-	190 / 180	-
Mo6	-	Mo6	-	Mo6	-
2,5 - 25	-	2,5 - 25	-	2,5 - 25	-
500 / 750		500 / 800		500 / 900	
0,27		0,27		0,27	
7 130 / 8 400 / 7 130		8 130 / 9 400 / 8 130		9 630 / 10 900 / 9 630	
5 150 / 3 100		5 150 / 3 100		5 150 / 3 100	
3 100 / 3 000		3 100 / 3 000		3 100 / 3 000	
25 000 - 30 500		26 500 - 32 500		28 500 - 35 000	
100	120	100	120	100	120
0,6 / 500	0,6 / 500	0,6 / 500	0,6 / 500	0,6 / 500	0,6 / 500
Siemens Sinumerik 840D SL		Siemens Sinumerik 840D SL		Siemens Sinumerik 840D SL	
5		5		5	

[] Special (optional) machine accessories, option. The machine conforms to 

Given the unceasing development and innovations of the machines, the data in this advertising material are subject to change without notice.

MULTICUT 630 technical data

Parameter		MULTICUT 630 / 6000			
		T	S		
Operating range	Max. swing over bed / lower support	mm	1 150 / 1 020		
	Max. turning diameter	B= 90° / 60° / 45° / 0°	790 / 930 / 1 060 / 1 150		
	Max. distance of faces	spindle to tailstock spindle spindle to spindle	6 400	6 400	
	Max. turning length <Z-axis travel>	mm	6 100		
	Bar capacity	mm	127		
Workpiece weight	Overhung / supported with rotary center, incl. chuck (max. 300 rpm)	kg	1 000 / 2 500		
	Supported with steady rests 1 / 2 / 3 incl. chuck (max. 300 rpm)	kg	3 000 / 3 500 / 4 000		
Linear axes of the tool spindle	X / Y <-Y/+Y> / Z axis travel	mm	780 / 400 <±200> / 6 100		
	Feed force X ; Y ; Z	25% / 40%ED / continuous	kN	20,5 / 17 / 12,0 ; 25 / 20,5 / 14,5 ; 25,5 / 20,5 / 14,5	
	X / Y / Z axis rapid traverse	m.min ⁻¹	40 / 30 / 40		
	X / Y / Z axis acceleration	m.s ⁻²	4 / 4 / 4		
Accuracy CSN ISO 230-2 VDI/DGQ 3441	Position accuracy X/Y/Z	mm	0,004 / 0,004 / 0,01		
	Repeatability X/Y/Z	mm	0,002 / 0,003 / 0,006		
Main spindle	Max. spindle speed	Low speed	min ⁻¹	720	
		High speed	min ⁻¹	2 800	
	Nominal spindle speed		min ⁻¹	194 / 972	
	Gear steps number			2	
	Spindle nose type (DIN 55026)			A11	
	Spindle boring		mm	135	
	I.D. of the front bearings		mm	200	
	Torque	Low speed 25% / 40% / 60% ED / continuous	Nm	- / - / 3 283 / 2 736	
		High speed 25% / 40% / 60% ED / continuous	Nm	930 / 821 / 657 / 547	
	Motor power	25% / 40% / 60% ED / continuous	kW	70 / 61,5 / 49 / 41	
Spindle axis height		mm	1 325		
Subspindle	Max. spindle speed	Low speed	min ⁻¹	-	720
		High speed	min ⁻¹	-	2 800
	Nominal spindle speed		min ⁻¹	-	194 / 972
	Gear steps number			-	2
	Spindle nose type (DIN 55026)			-	A11
	Spindle boring		mm	-	135
	I.D. of front bearings		mm	-	200
	Torque	Low speed 25% / 40% / 60% ED / continuous	Nm	-	- / - / 3 110 / 2 592
		High speed 25% / 40% / 60% ED / continuous	Nm	-	881 / 762 / 622 / 518
Motor power	25% / 40% / 60% ED / continuous	kW	-	73 / 63 / 51,5 / 43	
C-axis of workpiece spindles	Min. programming step			0,0001°	
	Max. speed	min ⁻¹		30	
	Torque	25% ED / continuous	Nm	2 176 / 1 408	
	Brake		Nm	3 000	
Tool spindle	Max. speed	min ⁻¹		12 000 [10 000; 6 500; 3 500]	
	Nominal speed	min ⁻¹		2 000 [2 500; 1 400; 1 500]	
	Taper			HSK 63 [Capto C6; HSK 100; Capto C8]	
	Torque	25% / 40% ED / continuous	Nm	162/143/119 [216/180/140; 300/255/200; 345/300/242]	
	Power	25% / 40% ED / continuous	kW	34/30/25 [56/47/37; 44/38/29; 54/47/38]	
	Number of tool indexing positions			continuous [24 × 15°; 24 × 15°; 24 × 15°]	
	Spindle length		mm	695 [580; 580; 580]	
B axis of tool spindle	Range			-120° / +120°	
	Min. programming step			0,00001°	
	Max. speed	min ⁻¹		50	
	Time of indexing by 90°		s	0,8	
	Torque	40% ED / continuous	Nm	1 300 / 750	
Hydraulic brake / locking		Nm	8 000 [1 700 / 8 200]		
Tool magazine	Tool storage capacity	HSK-T63, Capto C6		66 [120; 180]	
		HSK-T100, Capto C8		44 [80; 120]	
	Max. tool length		mm	500	
	Max. tool diameter	With / without adjacent HSK-T63, Capto C6	mm	175 / 90	
		With / without adjacent HSK-T100, Capto C8	mm	200 / 130	
	Max. tool weight		kg	12	
Tool to tool / chip to chip change time		s	3 / 10		
Tailstock	Tailstock spindle diameter / Tailstock spindle travel		mm	190 / 180	-
	Taper for rotary center	Morse		Mo6	-
	Thrust force range		kN	2,5 - 25	-
Coolant tank	Tank capacity / Coolant volume		l	500 / 1000	
	Pump motor power	continuous	kW	0,27	
Machine dimensions	Machine length without / with chip conveyor / for transport		mm	11 130 / 12 400 / 11 130	
	Machine width / for transport		mm	5 150 / 3 100	
	Machine height / for transport		mm	3 100 / 3 000	
	Machine weight		kg	30 000 - 36 500	
Machine connection	Electrical power supply	continuous	kVA	100	120
	Compressed air supply	pressure / flow	MPa/L.min ⁻¹	0,6 / 500	0,6 / 500
Control system	Type			Siemens Sinumerik 840D SL	
	Number of continuously controlled axes for machining			5	

MULTICUT 630 technical data

Parameter		MULTICUT 630 1500 / 2000 / 3000	
		T	S
Lower turret	Maximum number of heads	-	1
	Head size	-	25
	Number of positions / number of driven	-	12 / 12
	VDI size [Capto]	-	50 [C6]
	Machine swing limitation	mm	630
	Swing of the head with tools	mm	720
	Max. tools speed	min ⁻¹	4 000
	Torque 40% ED / continuous	Nm	65 / 26
	Output 40% ED / continuous	kW	20,4 / 8,2
	X / Z axis travel	mm	325 / 1300 (1800, 2800)
	X / Z axis rapid traverse	m.min ⁻¹	30 / 30
	X / Z axis acceleration	m.s ⁻²	0,4

[] Special (optional) machine accessories, option. The machine conforms to **CE**

Given the unceasing development and innovations of the machines, the data in this advertising material are subject to change without notice.



Remote diagnostics MAS MACHINE MONITOR

⇒ additional service that saves money

- Fastest technical and technological service for the customer
- Immediate "on-Line" contact with the customer's machine
- Inexpensive and reliable technical solution
- Experienced team of diagnosticians and application engineers - technologists

Remote diagnostics are the analysis of the machine's condition via communication software by a diagnostician. Using the communication software, the screen and the dialogue menu of the control system are remotely accessible via Internet. The actual communication software does not include any diagnostic tools. The service technician only remotely uses the internal diagnostic capabilities of the control system. The screen and the dialogue menu of the CNC are accessible from the service technician's computer at any distance. The technician not only monitors the current condition of the machine via his screen, but using the keyboard of his computer controls the CNC menu, transfers basically all data in both directions, and using the CHAT function communicates with the operator. During machine failure analysis, the technician utilises all diagnostic functions integrated in the CNC.

The goal of Remote diagnostics is to shorten the downtime of the machine by precisely targeting the subsequent servicing activity. This brings especially a reduction of customer's losses arising from the machine downtime.

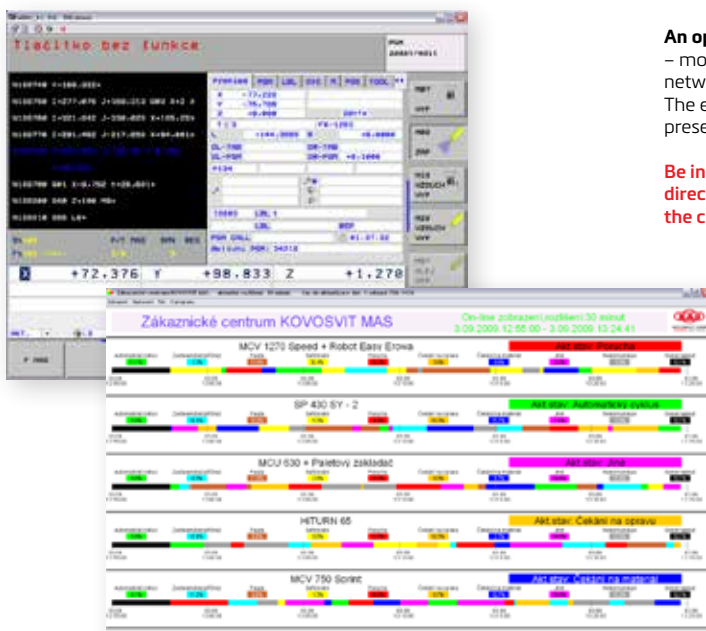

⇒ tool to increase the productivity of your plant!

MAS MACHINE MONITOR is a software product that allows the customer to monitor the time utilisation of machine during the shift online or allows to view the operating status history and to subsequently take measures in production and logistics. All this is possible in the visualisation program that is installed in the customer's PC.

MAS MACHINE MONITOR an arguable leap increase of your operation's productivity = YOUR PATH TO COMPETITIVENESS ENHANCEMENT THANKS TO THE MAS!

Basic functions of the MAS MACHINE MONITOR:

- Monitoring of utilisation of any number of machines, possibility of machine classifying into groups (workplaces)
- Online display of machine status or browsing through utilisation history
- Number of made pieces, display of power circuit start interval – electricity saving measures
- Summary statistics for individual machines
- Important information for company management and production control

An option of the MAS MACHINE MONITOR is the MAS GSM MONITOR

– monitoring of selected machine conditions via mobile phone operator network at selected phone numbers in the form of an SMS message. The employee can thus immediately react to an event even if he is not present near the machine at the moment.

Be independently and factually informed about the course of your jobs directly from the machine even during your physical absence from the company!

GSM MONITORING - function of the GSM MODULE:

Via the touch panel, it is possible to define up to 5 phone numbers that can be used for monitoring and controlling of the machine. SMS messages about machine condition changes are then sent to the entered phone numbers. The current condition of the machine can also be queried by sending an SMS reading "STATUS". The SMS can optionally be sent also upon meeting a certain condition (e.g. making a certain number of pieces etc.)

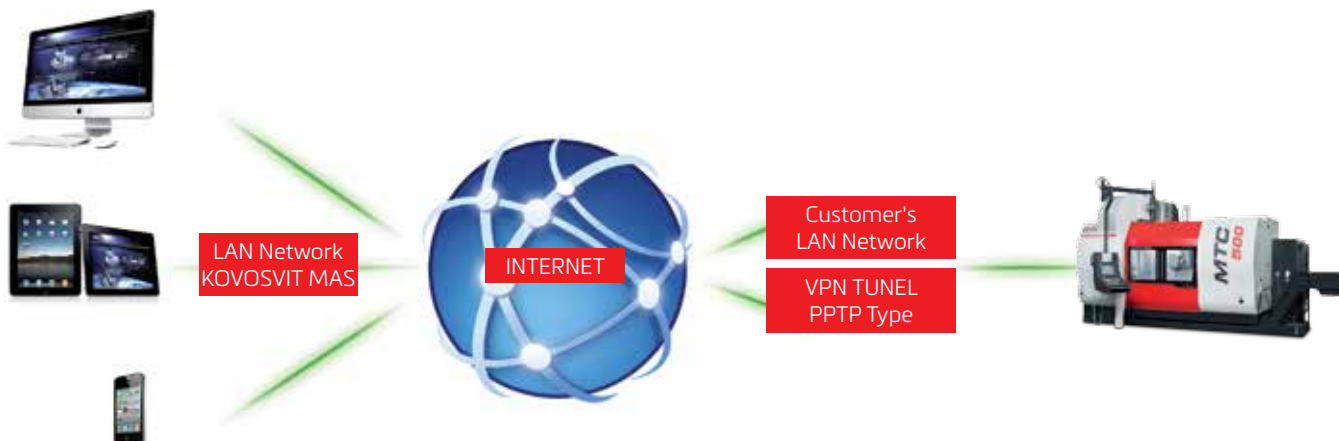



FOCUSED ON THE

POWER

ACCELERATION

RIGIDITY

FORCE

PRECISION

ERGONOMICS

STABILITY

MULTICUT

KOVOSVIT MAS, a.s.

náměstí Tomáše Bati 419, 391 02 Sezimovo Ústí
Czech Republic

T: T: +420 381 632 751, 381 632 586

F: +420 381 276 372

E: sale_export@kovosvit.cz

Service center MAS: +420 381 74 74 74



www.masmachinetools.com

<http://references.kovosvit.cz>



KOVOSVIT MAS
machine your future